

DESIGN NOTES

Number 5 in a series from Linear Technology Corporation

March, 1989

Temperature Measurement Using the LTC1090/91/92 Series of Data Acquisition Systems

William Rempfer
Guy Hoover

Introduction

Accurate temperature measurement is a difficult and very common problem. Whether recording a temperature, regulating a temperature or modifying a process to accommodate a temperature, the LTC1090 family of data acquisition systems can provide an important link in the chain between the blast furnace temperature and the microcontroller. Features of the LTC1090 family can make temperature measurement easier, cheaper and more accurate.

High DC input resistance and reduced span operation allow direct connection to many standard temperature sensors. Multiplexer options allow one chip to measure up to 8 channels of temperature information. Single supply operation, modest power requirements (~5mW) and serial interfaces make remote location possible. Switching power on and off lowers power consumption (560 μ W) even more for battery applications. Finally, because few sensors have accuracies as good as 0.1%, the 10-bit resolution and 0.05% accuracy of

the LTC1090 family are just right for most temperature sensing applications.

Thermocouple Systems

The circuit of Figure 1 measures exhaust gas temperature in a furnace. The 10-bit LTC1091A gives 0.5°C resolution over a 0°C to 500°C range. The LTC1050 amplifies and filters the thermocouple signal, the LT1025A provides cold junction compensation and the LT1019A provides an accurate reference. The J type thermocouple characteristic is linearized digitally inside the MCU. Linear interpolation between known temperature points spaced 30°C apart introduces less than 0.1°C error. The code for linearizing is available from LTC. The 1024 steps provided by the LTC1091 (24 more than the required 1000) insure 0.5°C resolution even with the thermocouple curvature.

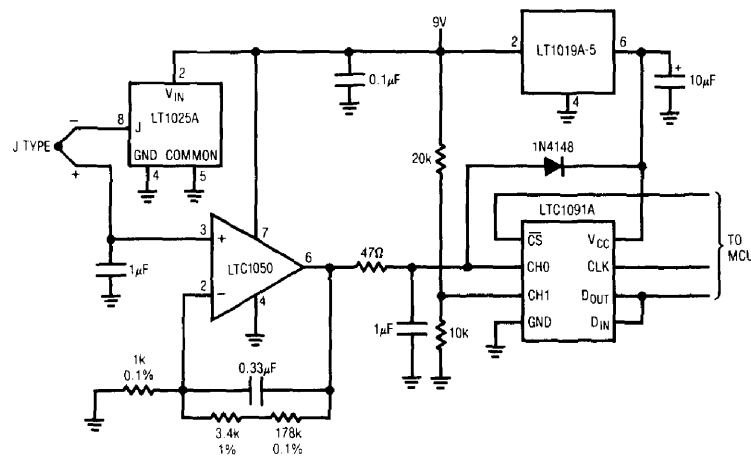

Figure 1. 0°C-500°C Furnace Exhaust Gas Temperature Monitor with Low Supply Detection

Offset error is dominated by the LT1025 cold junction compensator which introduces 0.5°C maximum. Gain error is 0.75°C max because of the 0.1% gain resistors and to a lesser extent the output voltage tolerance of the LT1019A and the gain error of the LTC1091A. It may be reduced by trimming the LT1019A or gain resistors. The LTC1091A keeps linearity better than 0.25°C. The LTC1050's 5µV offset contributes negligible error (0.1°C or less). Combined errors are typically 0.5°C or less. These errors don't include the thermocouple itself. In practice, connection and wire errors of 0.5°C to 1°C are not uncommon. With care, these errors can be kept below 0.5°C.

The 20k/10k divider on CH1 of the LTC1091 provides low supply voltage detection (the LT1019A reference requires a minimum supply of 6.5V to maintain accuracy). Remote location is easy, with data transferred from the MCU to the LTC1091 via the 3 wire serial port.

Thermilinear Networks

Figure 2 shows an 8 channel 0°C to 100°C temperature measurement system with 0.1°C resolution. The high DC input resistance and adjustable span of the LTC1090 allow it to measure the outputs of the YSI thermilinear components directly. Accuracy is limited by the sensor repeatability and precision resistors to 0.25°C.

Sensor input voltage (V_{IN}), not critical because of ratiometric operation, is set to around 1.5V to minimize self heating. The zero scale (COM pin) and full-scale (REF+ pin) of the LTC1090 are set by the precision resistor string to directly digitize the roughly 0.2V to 1V sensor output. The LT1006 buffers the 10kΩ reference resistance of the LTC1090. 0°C and 100°C

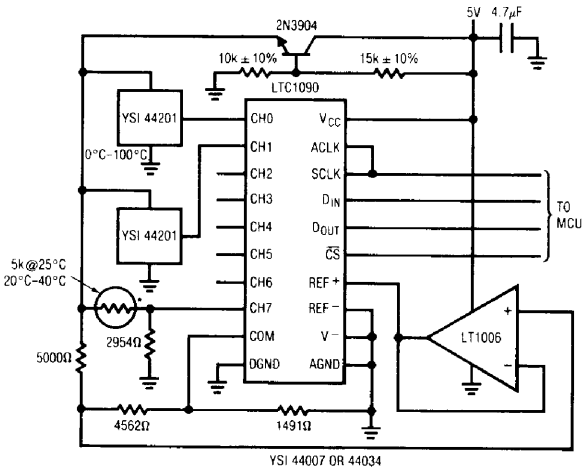

Figure 2. 0°C-100°C 0.25°C Accurate Thermistor Based Temperature Measurement System

correspond to unipolar output codes of 0 and 1000 (decimal), respectively with an overrange of 102.3°C.

Thermistors

A thermistor is a cheaper alternative to thermilinear components in narrower temperature range applications. In Figure 2, CH7 is being used to digitize the output of a 5kΩ thermistor. The resistor shown linearizes the output voltage around the 30°C point. The output remains linear to 0.1°C over a 20°C to 40°C range but gets nonlinear rapidly outside this range. By correcting for the non-linearity in software this range can be extended to 0°C to 60°C. Beyond that, the repeatability error of the thermistor increases above 0.2°C making correction difficult.

Silicon Sensors

Because of its high DC input impedance and reduced span capability, the LTC1090 family can directly measure the output of most industry standard silicon temperature sensors, both voltage and current mode. Popular sensors of this type include the LM134 and AD590 (current output) and silicon diodes.

Figure 3 shows a simple connection between the LTC1092 and industry standard 1µA/°K current output sensors. Resolution is 0.25°C and accuracy is limited by the sensor and resistors. Standard 10mV/°K voltage output sensors can also be connected directly to the LTC1092 input in a similar manner.

For LTC1090/91/92 literature call 800-637-5545. For help with an application call (408) 432-1900, Ext. 361.

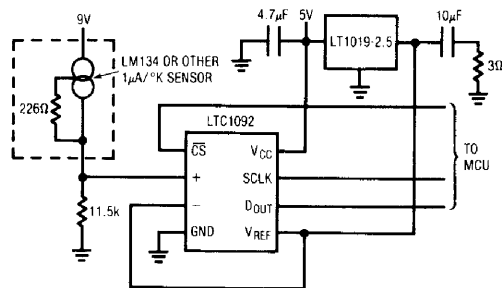

Figure 3. -55°C to +125°C Thermometer Using Current Output Silicon Sensors